

# Elevate Direct Glaze Round Tops

Unit Features.....	1
Minimum and Maximum Guidelines .....	2
Sizing Guidelines.....	3
Round Top Examples / Grilles-Between-the-Glass.....	4
Available Divided Lite Patterns.....	6
Section Details .....	8
Installation Suggestion - Brick Veneer with Steel Frame Construction .....	9
Installation Suggestion - Wood Siding with 2x6 Frame Construction.....	10
Installation Suggestion - Stucco with 2x4 Frame Construction .....	11



**Unit Features**

Elevate Direct Glaze Round Top: ELDG RT

For applicable certification and code information, refer to the Introduction and Product Performance chapter.

**Frame:**

- The frame exterior is made of Ultrex® fiberglass which is exceptionally resistant to thermal conductance. Ultrex frame is .094" (2 mm) thick. Available colors: Stone White, Pebble Gray, Bronze, Cashmere, or Ebony.
- The interior is non finger-jointed pine, kiln dried to a moisture content of 6-12% at time of fabrication. Water-repellent, preservative treated.
- Interior wood is available as Pine bare wood or factory applied white, clear, or designer black interior finishes.
- Frame width is 4 9/16" (116).
- 4/4 non finger-jointed pine interior stop is applied to all units.

**Jamb Extension:**

- Extension Thickness: 9/16" (14)
- Multiple depths available from 1/8" (3), 1/4"(6), and depths varying between 1/2"(13) and 4"(102) at 1/16" (2) increments
- Maximum jamb depth is 8 9/16". (217)
- 6 9/16" (167) or 6 13/16" (173) jamb extension - factory-applied
- All other jamb depth options are available shipped loose.
- Material: Bare Pine
- Option: factory applied white, designer black and clear lacquer interior finish

**Installation:**

- Integral nailing fin.
- Optional installation brackets available for round tops without nailing fin intended for masonry application.

**Glazing:**

- All units are manufactured with a glass thickness varying from 11/16" (17) to 1" (25) IG with Low E2, E3, E3/ERS, or E1 coatings including argon gas or air fill.
- Tempered glass and/or obscure, and California Fire glass (annealed exterior and tempered interior glazing configuration) glass are available as an option.
- STC/OITC values are available for 3.1 mm thickness glass.
  - Optional 3.1/4.7 STC/OITC upgrade glass is available. See Product Performance chapter for STC and OITC ratings.
- The glazing seal is a silicone bedding on the exterior surface with glazing tape on the interior.
- Decorative glass options include glue chip, rain, reed, narrow reed, frost, and tinted (bronze, gray or green). Decorative glass is not available with Low E1, Low E3/ERS or STC/OITC Upgrade options.

**Interior / Exterior Simulated Divided Lites (SDL):**

- Interior bar: 7/8" (22) wide bars. Pine bare wood or factory applied White, Clear, or Designer Black finishes to match the interior.
- Exterior straight bar: 7/8" (22) wide bars Ultrex, finish to match exterior
- Exterior radius bar: ABS Hi, HDT 7/8" (22) wide bars. Available in sunburst patterns with an open hub. Finish to match exterior.
- SDL with spacer bar available in standard sunburst patterns with an open hub. Not available on solid or closed hub patterns. Not available with rain, reed or narrow reed decorative glass. Glue chip requires tempered glass for SDL application. Tinted glass available without spacer bar only.

**Grilles-Between-the-Glass (GBG):**

- GBGs are manufactured from aluminum in an 23/32" (18) contoured profile placed between two panes of glass, available in standard sunburst patterns with a solid hub. Exterior color: Stone White, Pebble Gray, Bronze, Cashmere, or Ebony. Interior Colors: White, Bronze, or Black. Not available with tinted glass.

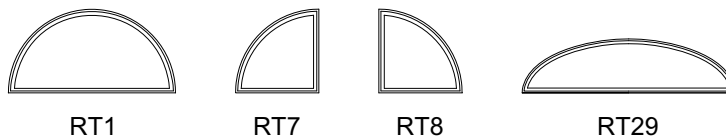

*NOTE: Drawings on this page are not to scale.*

Minimum and Maximum Guidelines

Minimum and Maximum Guidelines - Elevate Aluminum Direct Glaze Round Top								
Round Top Shape	Frame Size							
	Min Width		Min Height		Max Width		Max Height	
	in	mm	in	mm	in	mm	in	mm
<b>Aluminum Direct Glaze Round Top, Casement</b>								
Eyebrow Above Springline	20	(508)	17 15/16	(456)	72	(1829)	68 3/4	(1746)
True Half Above Springline	36	(914)	59 1/8	(1502)	72	(1829)	83 1/8	(2111)
True Half	31	(787)	16	(406)	72	(1829)	36	(914)
Quarter Round	24	(610)	24	(610)	24	(610)	24	(610)
Elliptical	72	(1829)	18	(457)	72	(1829)	18	(457)
<b>Aluminum Direct Glaze Round Top, Double Hung</b>								
Eyebrow Above Springline	24 1/2	(622)	19 7/16	(494)	83	(2108)	72 15/16	(1853)
True Half Above Springline	67	(1702)	69 1/4	(1759)	67	(1702)	69 1/4	(1759)
True Half	35 1/2	(902)	17 3/4	(451)	83	(2108)	41 1/2	(1054)
Quarter Round	29 1/2	(749)	29 1/2	(749)	35 1/2	(902)	35 1/2	(902)
Circle	35	(889)	35 1/2	(902)	35	(889)	35 1/2	(902)
Oval	31	(787)	47 1/2	(1207)	31	(787)	47 1/2	(1207)
Elliptical	71	(1803)	18	(457)	71	(1803)	18	(457)
<b>Aluminum Direct Glaze Round Top, Door</b>								
Eyebrow Above Springline	58	(1473)	32	(813)	71	(1803)	68 1/2	(1740)
True Half Above Springline	71	(1803)	58 5/8	(1489)	71	(1803)	58 5/8	(1489)
Elliptical	71	(1803)	18	(457)	71	(1803)	18	(457)

**Sizing Guidelines**

Round Top multiple assemblies can be factory mulled up to 3 units wide by 2 units high.

**MAXIMUM ROUGH OPENING:** 113 1/2" (2883) x 91 1/16" (2313) **or** 85" (2159) x 107 9/16" (2732)

*NOTE: Quarter Round shapes require a Casement with a continuous head jamb.*

**CALCULATING TOTAL ROUGH OPENING FOR ASSEMBLIES**

**WIDTH:** ADD Frame Widths + 1" (25)

Tolerance = 1/2" (13) from the frame to Rough Opening at left and right jamb.

**HEIGHT:** ADD Frame Heights + 1/2" (13)

Tolerance = 1/2" (13) from Frame to Rough Opening at head jamb.

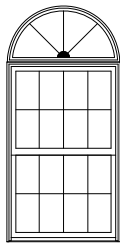

1 Wide 2 High

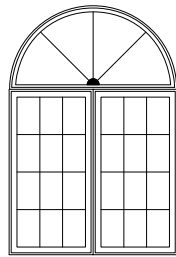

2 Wide 2 High

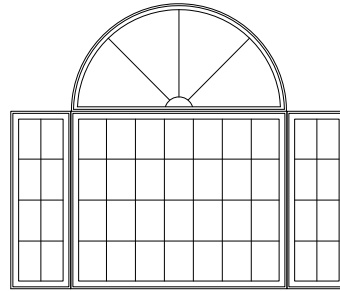

3 Wide 2 High

Unit Measurements		Width		Height	
From	To	in	mm	in	mm
<b>Rough Opening</b>		<b>in</b>	<b>mm</b>	<b>in</b>	<b>mm</b>
OM of Frame	Rough Opening	+ 1	(25)	+ 1/2	(13)
Masonry Opening	Rough Opening	+ 1/2	(13)	+ 1/4	(06)

**Round Top Examples / Grilles-Between-the-Glass**

**Casement**

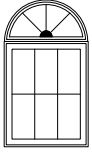

ELDGR29-1W  
ELCA 2935

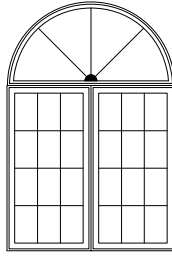

ELDGR29-2W  
ELCA 2955-2W

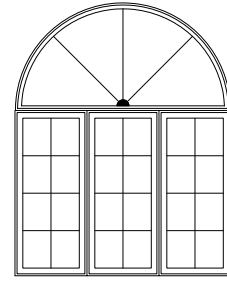

ELDGR25-3W  
ELCA 2555-3W

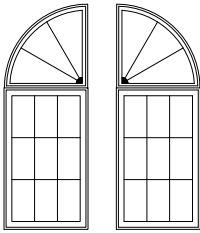

IQCIR29-1W  
ELCA 2947

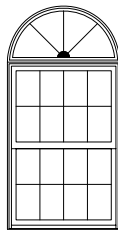

ELDGR38-1W  
ELDH 3856

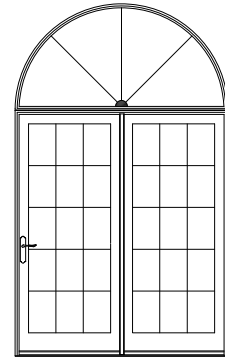

ELDGR 7236 / ELIFD 6068  
(Available field mullied only)

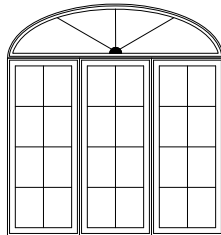

ELDGRCA7318  
ELCA 2559-3W

**Round Top Examples / Grilles-Between-the-Glass**

**Multiple Assemblies (examples)**

**Available Divided Lite Patterns**

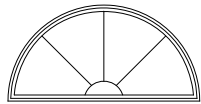

Open Hub, 3 Spokes  
Sunburst Lite Cut  
GBGs, SDL

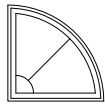

Open Hub, 1 Spoke  
Sunburst Lite Cut  
SDL

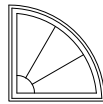

Open Hub, 2 Spokes  
Sunburst Lite Cut  
GBGs

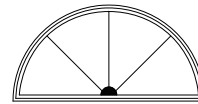

Solid Hub, 3 Spokes  
Sunburst Lite Cut  
GBGs

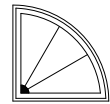

Solid Hub, 2 Spokes  
Sunburst Lite Cut  
GBGs

**DIVIDED LITE OPTIONS**

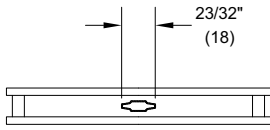

Aluminum Grille Between Glass

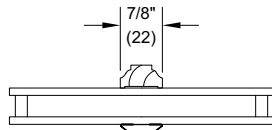

Simulated Divided Lite

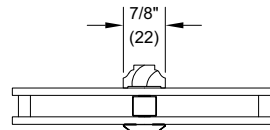

Simulated Divided Lite  
With Spacer Bar



Available Divided Lite Patterns

Sunburst Lite Pattern - GBG

Standard CN	Product Series	RT Shape	Unit Alignment	Sunburst Pattern Default	Sunburst Pattern Optional
29-1W	CA	RT7/RT8	ELCA 29-1W	Solid Hub, 2 Spokes	Open Hub, 2 Spokes
29-1W	CA	RT1	ELCA 29-1W	Solid Hub, 3 Spokes	Open Hub, 3 Spokes
21-2W	CA	RT1	ELCA 21-2W	Solid Hub, 3 Spokes	Open Hub, 3 Spokes
25-2W	CA	RT1	ELCA 25-2W, ELCA P 49-1W	Solid Hub, 3 Spokes	Open Hub, 3 Spokes
29-2W	CA	RT1	ELCA 29-2W, ELCA P 57-1W	Solid Hub, 3 Spokes	Open Hub, 3 Spokes
25-3W	CA	RT1	ELCA 25-3W, ELCA 37-2W	Solid Hub, 3 Spokes	Open Hub, 3 Spokes
7318	CA	RT29	ELCA 25-3W, ELCA 37-2W	Solid Hub, 3 Spokes	Open Hub, 3 Spokes
30-1W	DH	RT1	ELDH 30-1W	Solid Hub, 3 Spokes	Open Hub, 3 Spokes
34-1W	DH	RT1	ELDH 34-1W	Solid Hub, 3 Spokes	Open Hub, 3 Spokes
38-1W	DH	RT1	ELDH 38-1W	Solid Hub, 3 Spokes	Open Hub, 3 Spokes
34-2W	DH	RT1	ELDH 34-2W	Solid Hub, 3 Spokes	Open Hub, 3 Spokes
36-2W	DH	RT1	ELDH 36-2W	Solid Hub, 3 Spokes	Open Hub, 3 Spokes
7218	DH	RT29	ELDH 36-2W	Solid Hub, 3 Spokes	Open Hub, 3 Spokes
7236	DR	RT1	ELSPD, ELSFD, ELIFD, ELOFD 60-1W	Solid Hub, 3 Spokes	Open Hub, 3 Spokes
7218	DR	RT29	ELSPD, ELSFD, ELIFD, ELOFD 60-1W	Solid Hub, 3 Spokes	Open Hub, 3 Spokes

Sunburst Lite Pattern - SDL

Standard CN	Product Series	RT Shape	Unit Alignment	Sunburst Pattern Default
29-1W	CA	RT7/RT8	ELCA 29-1W	Open Hub, 1 Spoke
29-1W	CA	RT1	ELCA 29-1W	Open Hub, 3 Spokes
21-2W	CA	RT1	ELCA 21-2W	Open Hub, 3 Spokes
25-2W	CA	RT1	ELCA 25-2W, ELCA P 49-1W	Open Hub, 3 Spokes
29-2W	CA	RT1	ELCA 29-2W, ELCA P 57-1W	Open Hub, 3 Spokes
25-3W	CA	RT1	ELCA 25-3W, ELCA 37-2W	Open Hub, 3 Spokes
7318	CA	RT29	ELCA 25-3W, ELCA 37-2W	Open Hub, 3 Spokes
30-1W	DH	RT1	ELDH 30-1W	Open Hub, 3 Spokes
34-1W	DH	RT1	ELDH 34-1W	Open Hub, 3 Spokes
38-1W	DH	RT1	ELDH 38-1W	Open Hub, 3 Spokes
34-2W	DH	RT1	ELDH 34-2W	Open Hub, 3 Spokes
36-2W	DH	RT1	ELDH 36-2W	Open Hub, 3 Spokes
7218	DH	RT29	ELDH 36-2W	Open Hub, 3 Spokes
7236	DR	RT1	ELSPD, ELSFD, ELIFD, ELOFD 60-1W	Open Hub, 3 Spokes
7218	DR	RT29	ELSPD, ELSFD, ELIFD, ELOFD 60-1W	Open Hub, 3 Spokes

**Section Details**

**CASEMENT**

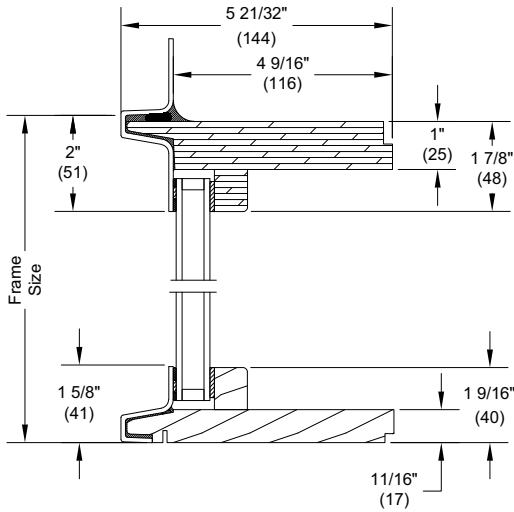

**DOUBLE HUNG / PATIO DOOR**

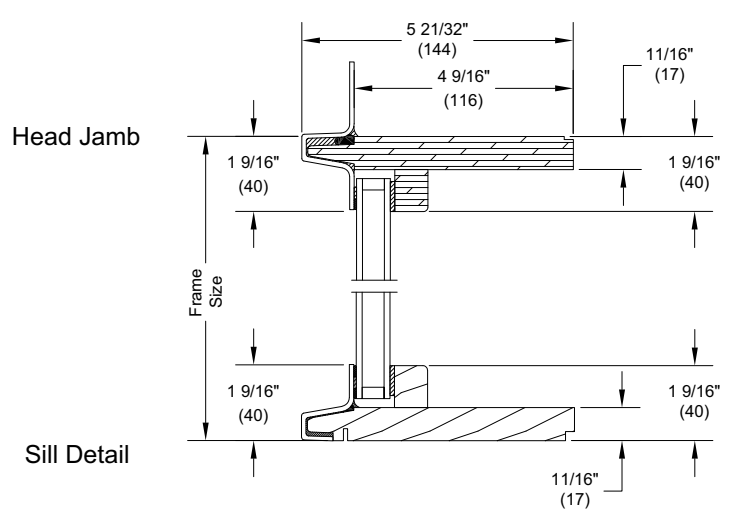

Head Jamb

Sill Detail

**MULLIONS**

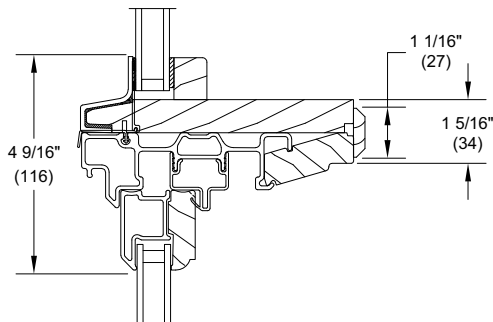

Double Hung Round Top Over  
Double Hung Operator

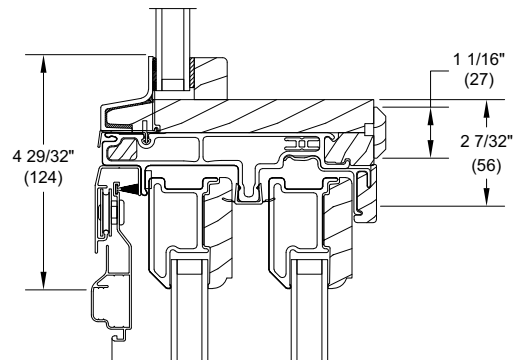

Double Hung Round Top Over  
Integrity Patio Door

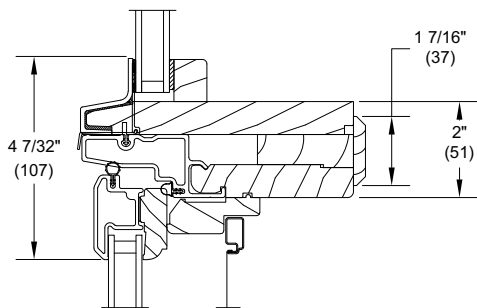

Casement Round Top Over  
Casement Operator

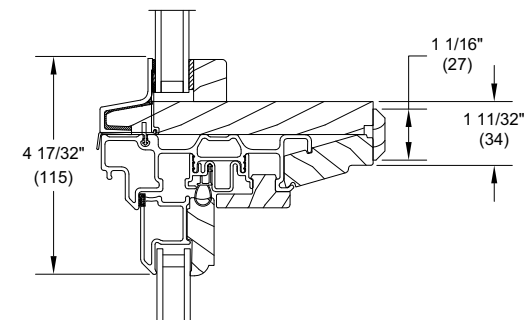

Double Hung Round Top Over  
Double Hung Picture Unit

**Installation Suggestion - Brick Veneer with Steel Frame Construction**

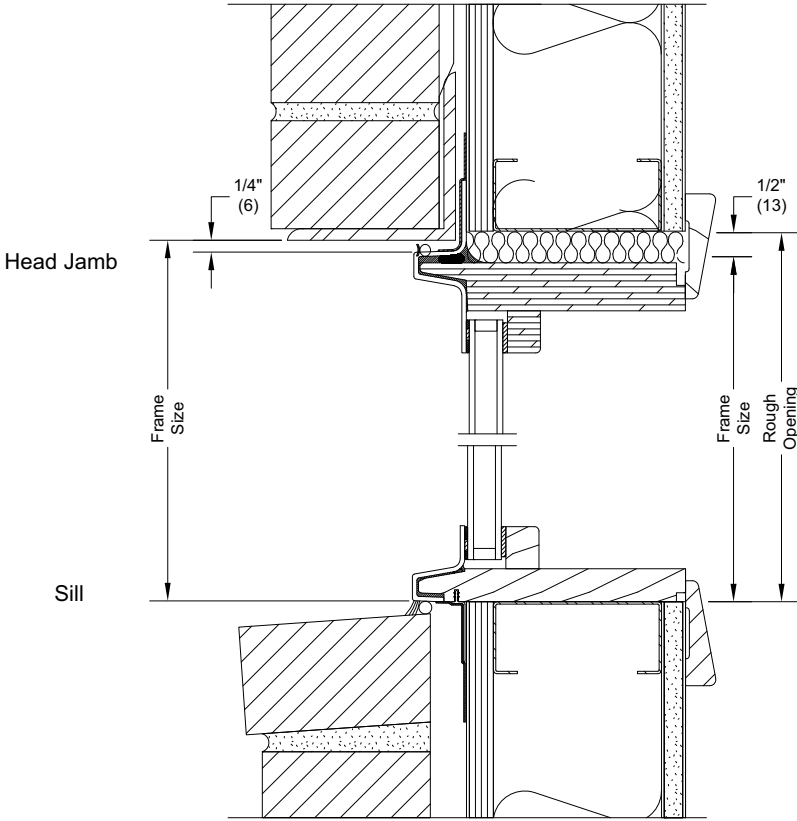

**Installation Suggestion - Wood Siding with 2x6 Frame Construction**

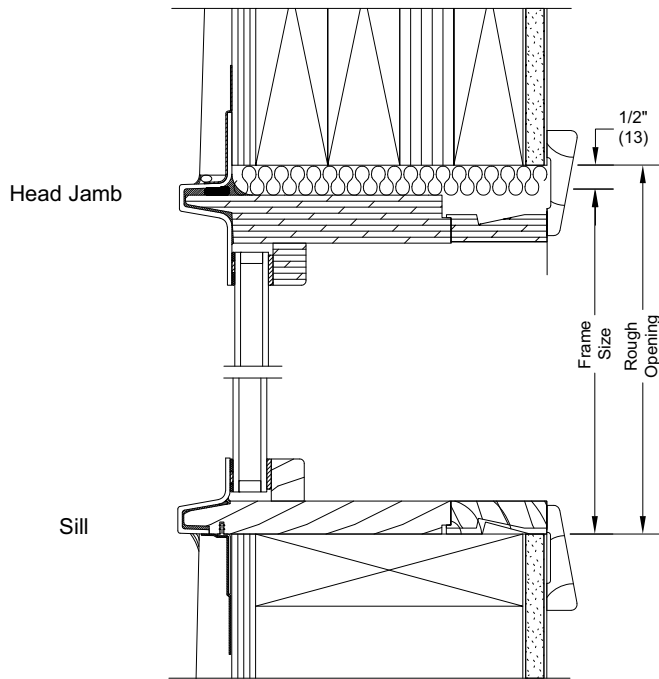

**Installation Suggestion - Stucco with 2x4 Frame Construction**

