

Skycove

Installation Instruction for Wood Construction

ABSTRACT: Please read these instructions in their entirety before beginning to install your Marvin product. These installation instructions demonstrate the installation of a Skycove unit in new wood frame construction using an industry approved water management system. For installation using other construction methods, such as remodeling, replacement, and recessed openings refer to “ASTM E2112, Standard Practice for Installation of Exterior Windows, Doors and Skylights,” for installation suggestions. Information for ASTM E2112 can be found on the ASTM website, www.astm.org For product specific issues, service instructions and other field service guides, visit our website at www.marvin.com, or contact your Marvin representative.

Regional standard practices, environmental conditions, and codes may vary and supersede the procedures contained within. The responsibility for compliance is yours: the installer, inspector, and owner(s).

The procedures within these instructions are consistent with those used in testing to achieve the advertised DP rating.

The English language version of this Installation Instruction is the official version and shall take precedence over any translation.

This instruction is relevant for products manufactured September 2020 to present.

NOTE: Numbers listed in parentheses () are metric equivalents in millimeters rounded to the nearest whole number.



Fastener Kits (Included in Job Box)

Kit A- Unit Adjustment Kit		
Image Letter	Description	Quantity
a	Unit Adjustment Bracket	2
b	3/8" x 10" Carriage Bolt	2
c	3/8" x 6" Carriage Bolt	2
d	3/8" Washer	2
e	3/8" Nut	2

Kit B- Shimming Kit		
Image Letter	Description	Quantity
b	3/8" Lag Bolt	6
d	3/8" Washer	6
	1/8" Shim Stack	6

Kit C- Wood Installation Bracket Kit (4 Kits per Unit)		
Image Letter	Description	Quantity
g	5/16" x .625" Bolt	5
h	5/16" Washer	5
i	1/2" x 6" Lag Bolt	3
j	1/2" Washer	5
k	1/2" x 13" Threaded Rod	1
l	1/2" Nut	4

Kit D- Modular Installation Kit		
Image Letter	Description	Quantity
m	#8-18 x .4375" Tek 2 PH Screw	14

Kit E- Header Support Kit		
Image Letter	Description	Quantity
n	1/4" x 3 1/8" Washer Head Screw	22
m	#8-18 x .4375" Tek 2 PH Screw	14

Kit F- Sill Shim Kit		
Image Letter	Description	Quantity
o	Adhesive Backed Shims	4
p	Weep Tape	4

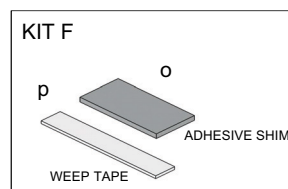
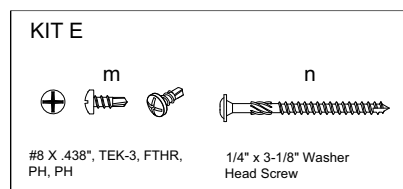
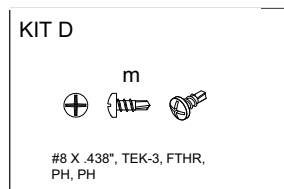
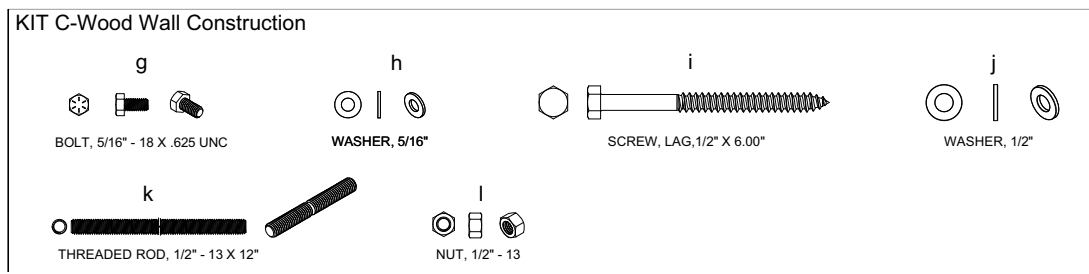
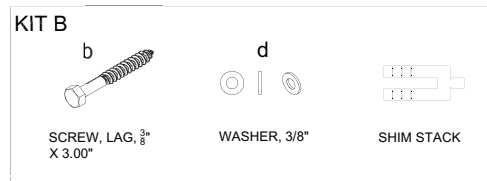
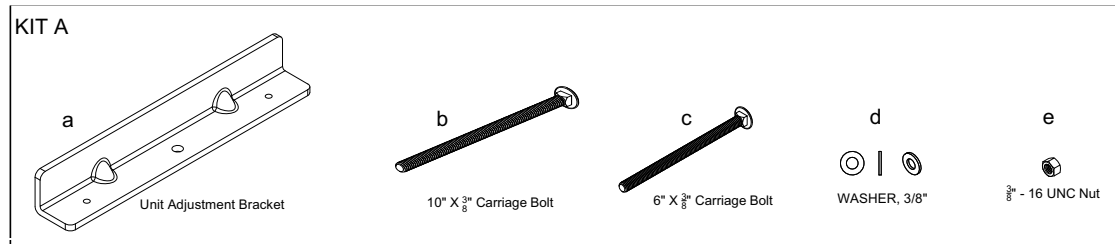

Other Items Included with Skycove Unit

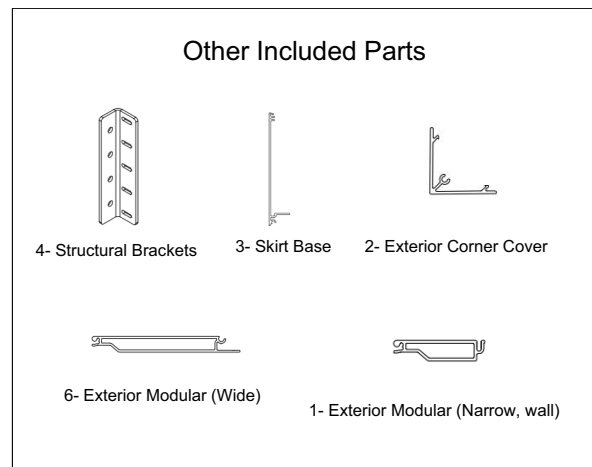
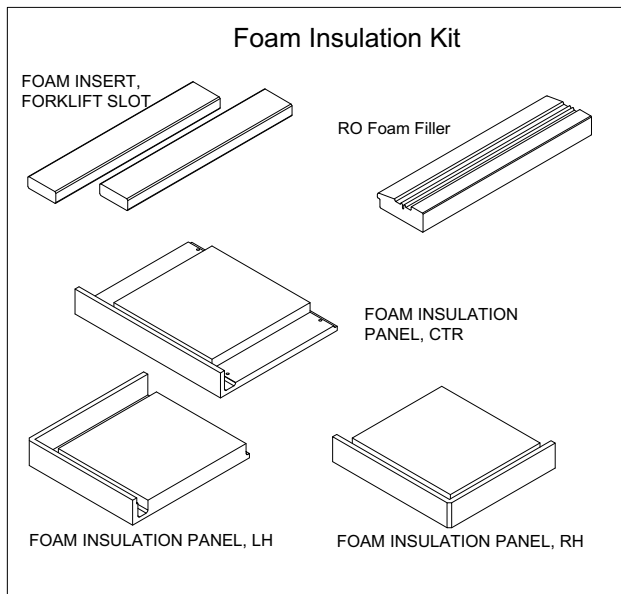

Kit C-Steel/Concrete Wall Construction (Optional)



5- BOLT, 5/16" - 18 X .625 UNC



5- WASHER, 5/16"

Tools and Supplies Needed

- Safety glasses
- Hearing protection
- 2 x 4 Lumber (for back dam)
- Level
- Square
- Perimeter sealant
- Sill pan flashing
- Torque wrench
- Low expansion foam insulation
- Flashing material
- Weather resistive barrier
- Power impact driver (T20 and Phillips bits)
- Power drill (1/4", 3/8" and extended 1/2" drill bits)
- Deep well socket set (1/2", 9/16" and 3/4" sockets)
- Tape Measure
- Forklift with maximum fork size of 4-1/2" x 1-1/2"

01. Rough Opening Preparation

1. Make horizontal cuts to the Weather Resistive Barrier (WRB) across the top and bottom of the Rough Opening. See Figure 1.

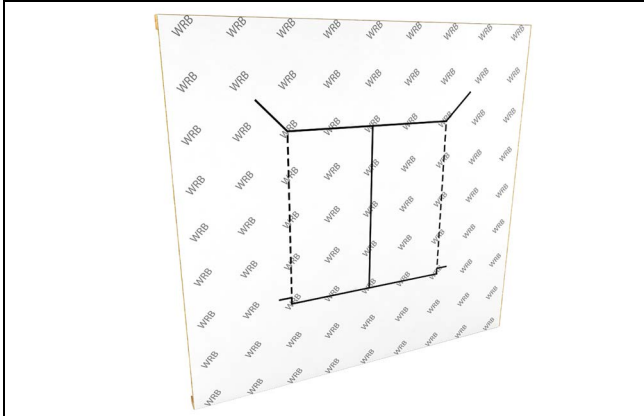

Figure 1

2. Trim up from the bottom corners about 2" (51) and then make an additional horizontal cut about 3 1/2" (89) wide. See Figure 2.

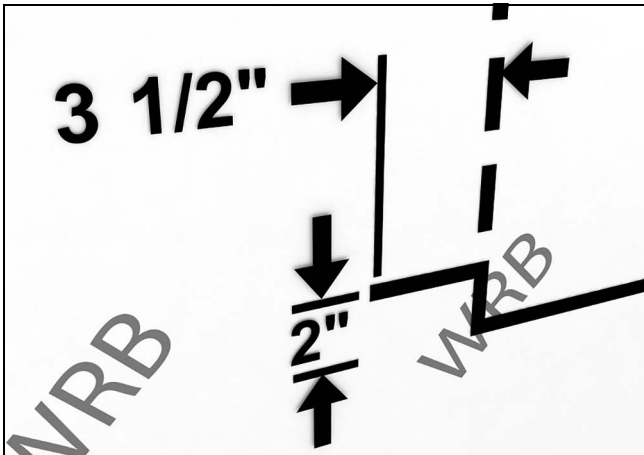

Figure 2

3. Make a vertical cut down the center of the RO. Then make a 45 degree cuts away from the corners of the top of the RO. See Figure 3

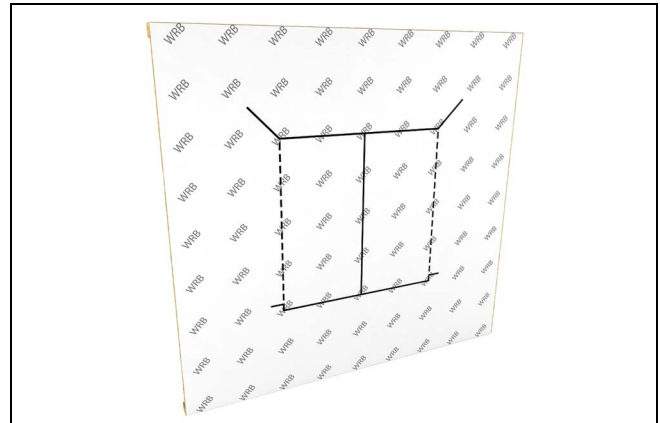

Figure 3

4. Flip top flap up and tack in place temporarily. Tack the side flaps away until sill flashing is installed. See Figure 4.



Figure 4

5. Apply the self sealing flexible membrane to the sill. See Figure 5.

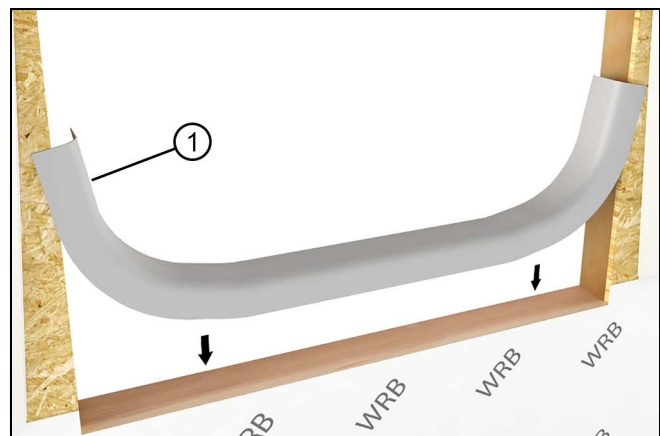

Figure 5

6. Wrap side flaps to the interior and staple in place about 1 1/2" (38) from the interior edge of the opening. Cut the excess off near the staple so that a 1"- 1 1/2" (25-38) strip of bare wood is exposed. Tape the edge with seam seal tape. See Figure 6.

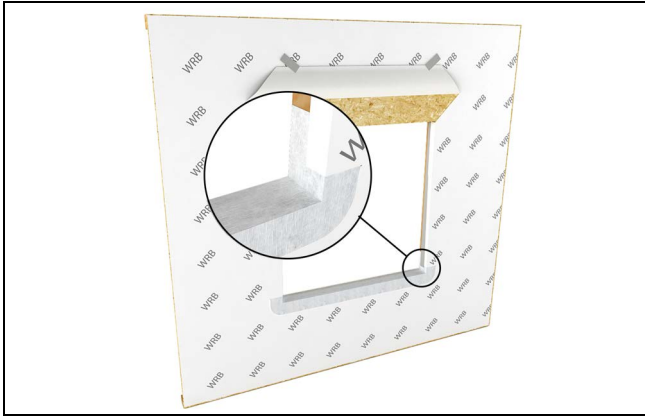

Figure 6

7. Apply seam seal tape over the corners. See Figure 7.

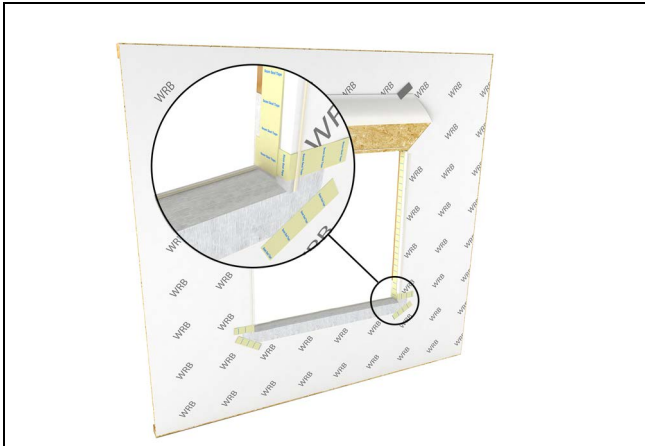

Figure 7

8. Using **Kit F**, apply four adhesive backed shims applied to sill. See Figure 8.

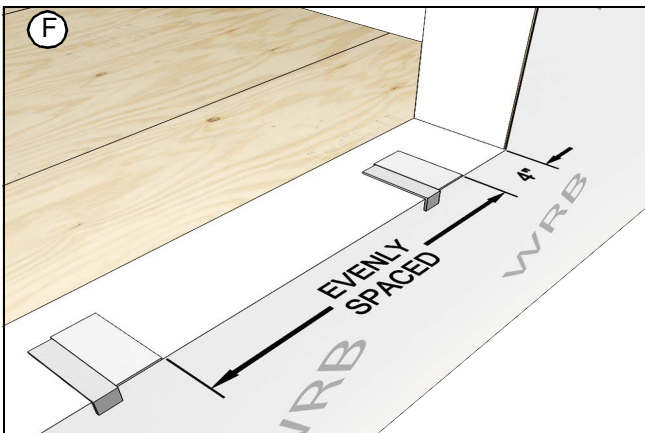

Figure 8

9. Apply foam weep tape next to shims. See Figure 9. 1-1/2" (38) wide x 5" (127) long. Fold over exterior of sill pan and hang over an 1" (25). See Figure 10.

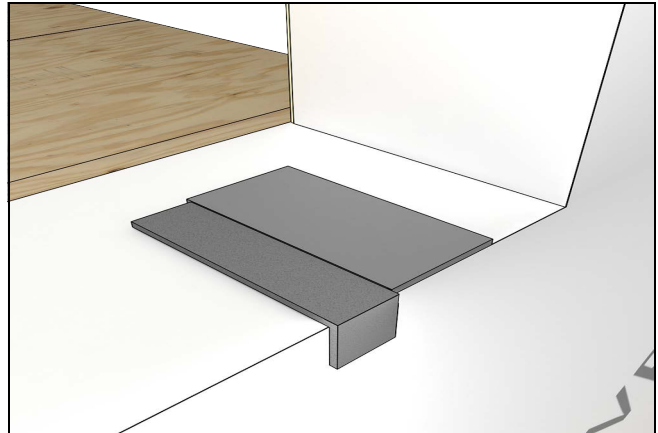

Figure 9

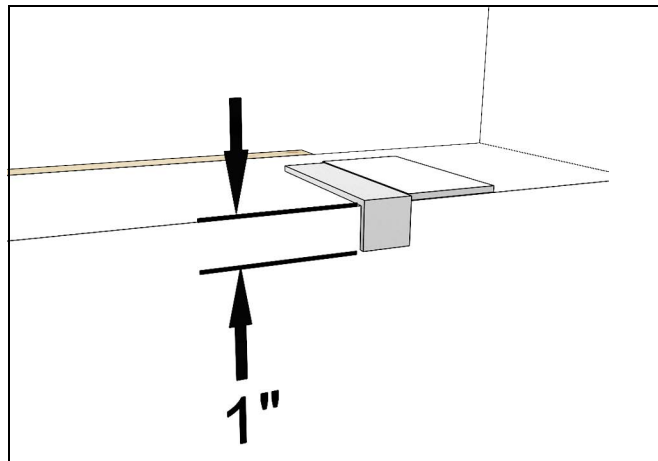

Figure 10

02. Prepping the Unit

WARNING!

Do NOT lift or move without proper equipment. Read, understand, and follow all lift equipment manufacturers' instructions and safety information.

1. Max fork size of 4-1/2" x 1-1/2" to be used. See Figure 11.

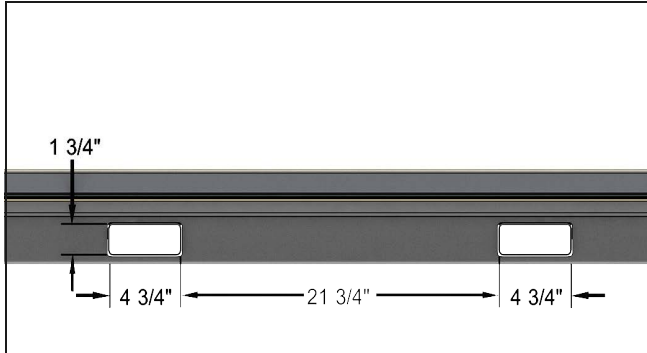

Figure 11

IMPORTANT

Exterior accessory parts are located on the removable side of the crate. Save these for later steps.

2. Cut and remove the protective packaging from the unit and dispose/recycle properly. See Figure 12. Inspect unit for any hidden damage and report immediately to your Marvin representative. Carefully set aside finished parts, job box, and foam box located within the crating system. Remove crating.

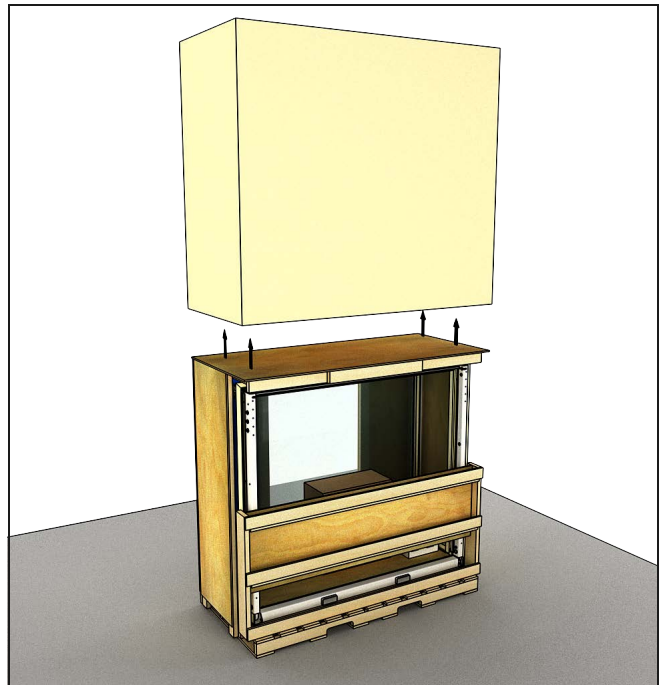

Figure 12

IMPORTANT

Leave unit on pallet base until ready to install to avoid damage to the flashing flange.

3. Remove all T-20 screws around the exterior of the crate, starting with the top panel first, to disassemble. See Figure 13.

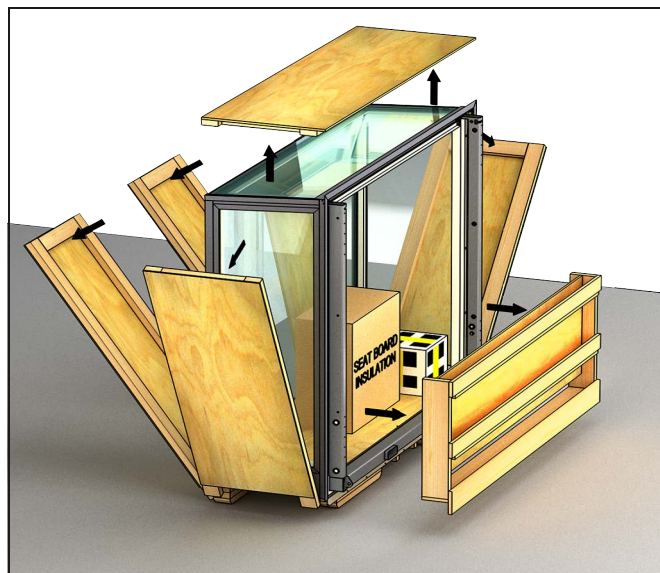

Figure 13

03. Positioning the Unit into the Rough Opening

IMPORTANT

Measure or dry fit unit into the rough opening prior to sealant application.

1. Add continuous perimeter seal along the head and jamb sides of the aluminum flashing flange prior to installing window into rough opening for exterior air and water seal. See Figure 14.

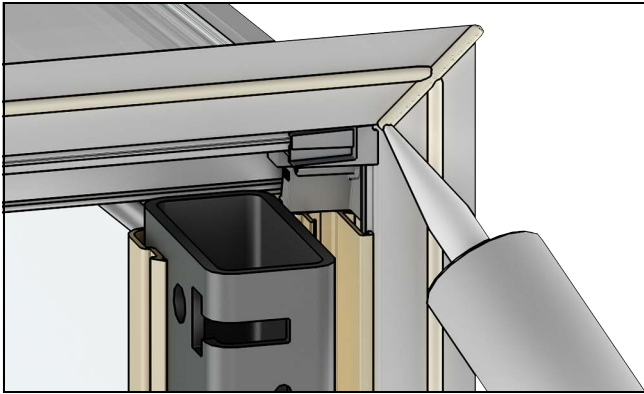

Figure 14

IMPORTANT

Over-tightening the nut on the carriage bolt could damage the window frame. Use care to tighten only to pull the unit tight to the exterior sheathing.

2. Using the top panel of the disassembled shipping crate, space between the mast of forklift and unit to avoid damage. Move the unit into the R.O. until the exterior flashing flange profiles rest against the outside sheathing of wall. See Figure 15.



Figure 15

IMPORTANT

To prevent damage of flashing flange profile during installation, install unit as level as possible to prevent bending of parts. See Figure 16.

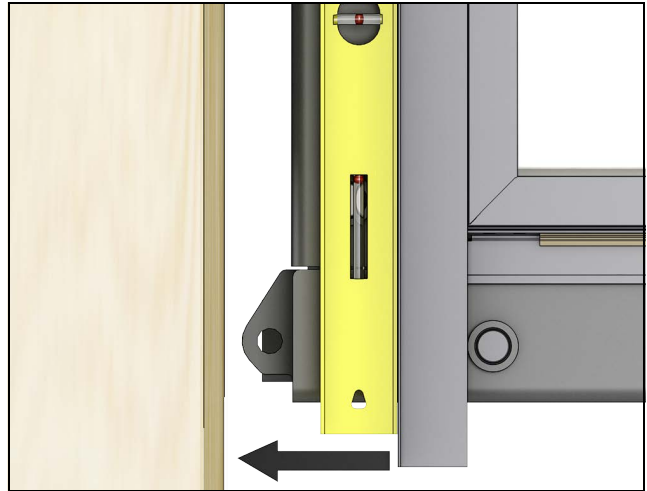

Figure 16

IMPORTANT

Measure or dry fit unit into the rough opening prior to sealant application.

3. Ensure unit is level by adding flat shims as needed on top of shims previously applied. Shim the ends of the steel structure and every 24"(610) along sill plate. See Figure 17.



Figure 17

04. Unit Adjustment Brackets

IMPORTANT

Measurements are done to the unit, not the steel structure, to ensure proper installation and preferred contact with exterior sheathing for easier flashing and finishing.

1. Make sure your unit is plumb, level and square. See [Figure 18](#).



Figure 18

2. Hold unit adjustment bracket (**Kit A**) across the interior of the rough opening. Note: #8 screws (not included) could be used to temporarily hold unit adjustment bracket in place). See [Figure 19](#).



Figure 19

3. Insert plumbing carriage bolt into the upright steel tube and unit adjustment bracket. Two lengths of carriage bolts are provided for varying wall depths. Tighten and pull unit into rough opening so exterior flashing flange is pulled tight to the exterior sheathing. See [Figure 20](#).



Figure 20

IMPORTANT

Over-tightening the nut on the carriage bolt could damage the window frame. Use care to tighten only to pull the unit tight to the exterior sheathing.

05. Pre-Installation Fastening

1. Pre-drill lag bolts using 1/4" (6) drill bit. Install provided 3/8" (10) x 3"(76) lag bolts and washers (**Kit B**) through the fabricated holes in the upright steel structure to fasten it to the R.O. [See Figure 21](#). Rotate shims to clear brackets.

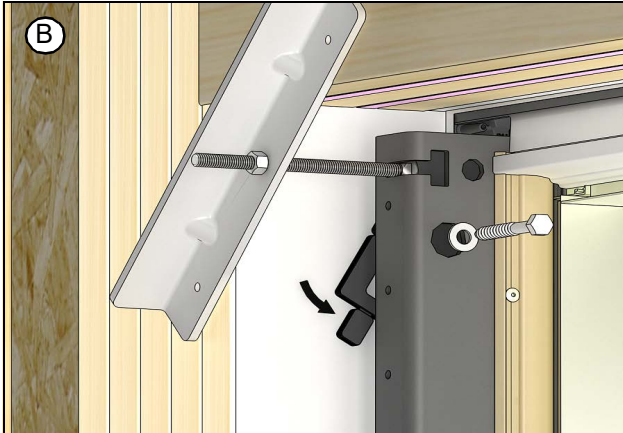

Figure 21

IMPORTANT

Lag bolts are not the final structural member. Once these lag bolts are installed, unit is no longer adjustable. Ensure level, plump, and square prior to installing these bolts. Shims are required behind all installed lag bolts. [See Figure 22](#).

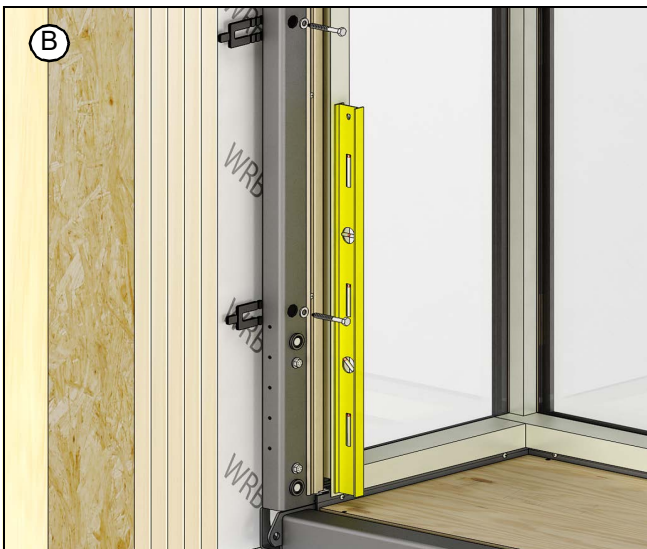

Figure 22

IMPORTANT

Under-shimming could cause rotation of the steel tube which could result in gaps of your interior covers.

06. Jamb Fastening Detail

IMPORTANT

To ensure structural strength, the steel L-bracket must be installed in correct order as listed below.

1. Place steel structural bracket against upright steel tube using a 5/16" (8) bolts and washers (Kit C). Snug up brackets to steel, still allowing it to slide to contact the rough opening. Do not fully tighten at this time. See [Figure 23](#).

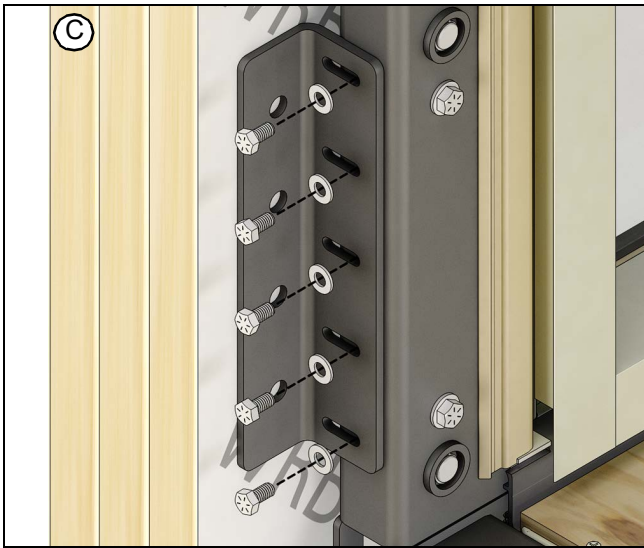

Figure 23

2. Using a 5/16" (8) drill bit and the installation bracket as a guide, pre-drill for lag bolts. Slide Installation brackets tight into RO. Pre-drill with offset close to the inside of the RO in bracket. See [Figure 24](#).

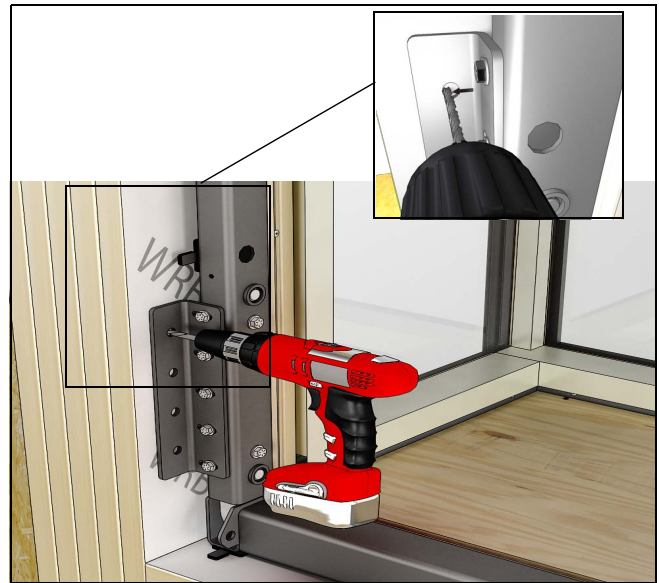

Figure 24

3. Fasten the Installation brackets tight to the RO using 1/2" (13) lag bolts and washers (Kit C). See [Figure 25](#).

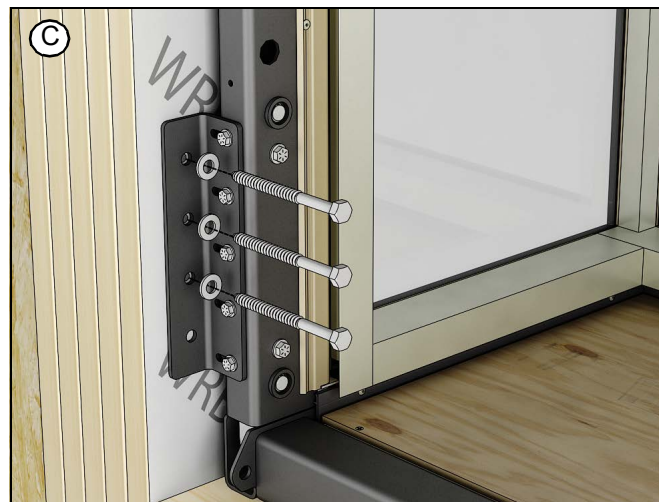

Figure 25

4. On bottom hole of bottom bracket and top hole of top bracket, pre-drill through all studs using an extended 1/2" (13) drill bit. See Figure 26.



Figure 26

5. Pre-assemble and install threaded rod by placing a washer and two nuts on interior side. Thread through all studs and place washer and two nuts on opposing side. Ensure that the interior side does not extend past the upright steel tube to not interfere with finishing details. Tighten appropriately. Repeat on all structural brackets See Figure 27.



Figure 27

6. Using a torque wrench, torque the 5/16" (8) bolts tight to the upright steel structure to 20 +/- 2 foot pounds. You can remove the unit adjustment brackets at this time to access all of the machine bolts on the top brackets. See Figure 28.

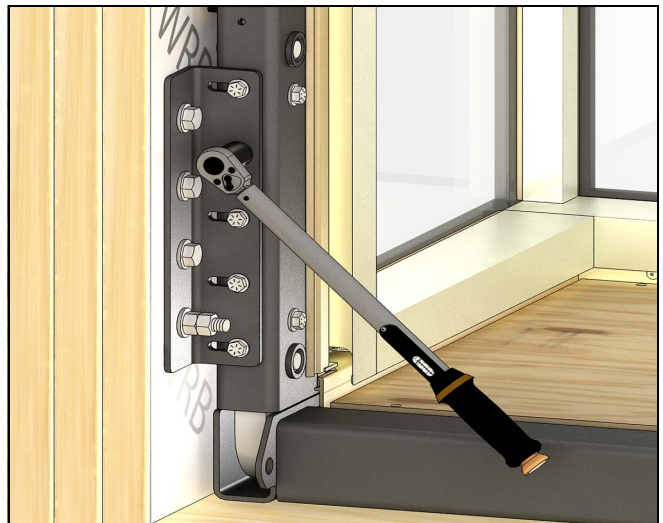

Figure 28

IMPORTANT

It is now safe to remove the forklift.

07. Head Fastening Details

1. Locate frame support bracket in accessory crate.
2. Position frame support bracket so that it fully engages with unit. Using fasteners from **Kit E** (1/4" x 3-1/8" washer head screws), fasten Frame Support Bracket to head jamb of rough opening. See [Figure 29](#) and [Figure 30](#).



Figure 29

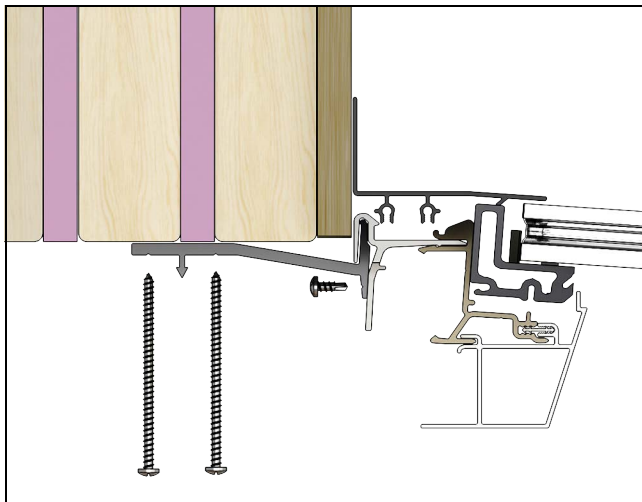

Figure 30

3. Use a level to ensure the cover is aligned correctly. See [Figure 31](#). The center may need to be supported to eliminate sagging while installing fasteners in the next step.



Figure 31

4. Using fasteners in **Kit E** (#8-18 x.4375") attach the Frame Support Bracket to the installed aluminum frame component by screwing through the pre-punched hole in the Frame Support Bracket into the wall of the installed aluminum profile. See [Figure 32](#).



Figure 32

08. Finishing and Flashing

1. Remove exterior aluminum covers from inside the crate.
2. Remove the 2" X 8" X 20" foam from inside the foam box. Install into the installation holes of the steel frame ensuring the foam is flush to the outside of the steel structure. See Figure 33.

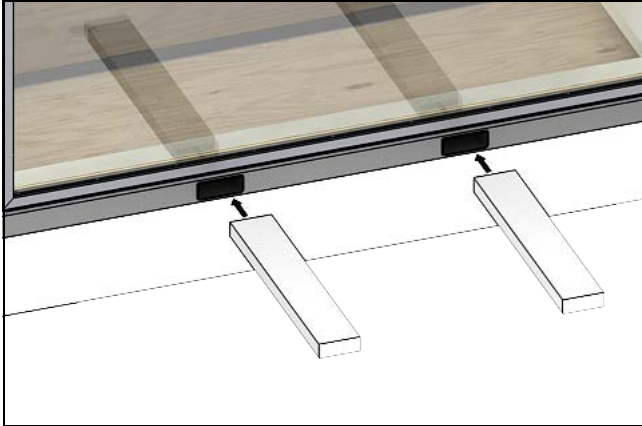

Figure 33

3. Install foam panels by aligning handed parts onto the bottom of the steel structure until it is fully seated against the steel structure. ("LH" means the left hand panel, which will be on the left hand side of the unit as you look at it from exterior.) See Figure 34.

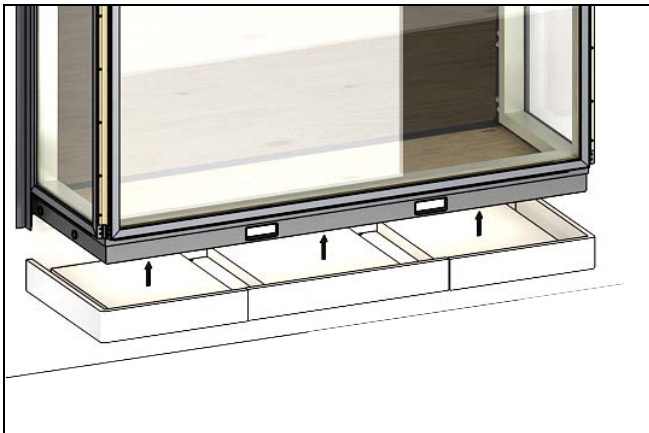

Figure 34

IMPORTANT

Remaining foam components used for interior rough opening insulation. Refer to interior finishing details for instructions.

4. Install both the front and side skirting profiles. See Figure 35. Starting at one end, use a hammer and block to fully seat the aluminum attachment feature into the provided kerf. See Figure 36.

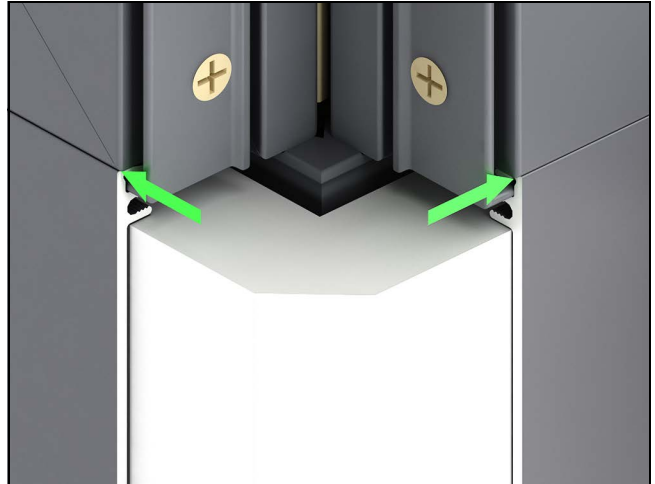

Figure 35



Figure 36

5. Install exterior corner cap profiles to both exterior corners. See Figure 37, Figure 38, and Figure 39. Ensure plastic part is at the bottom and engages with both the side and front skirt pieces. Parts are handed. At the top of the part, ensure the 4° angle are on the sides of the unit, not the front.



Figure 37

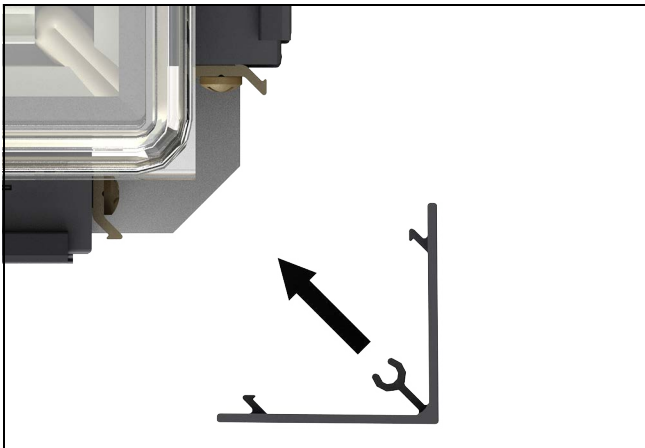

Figure 38

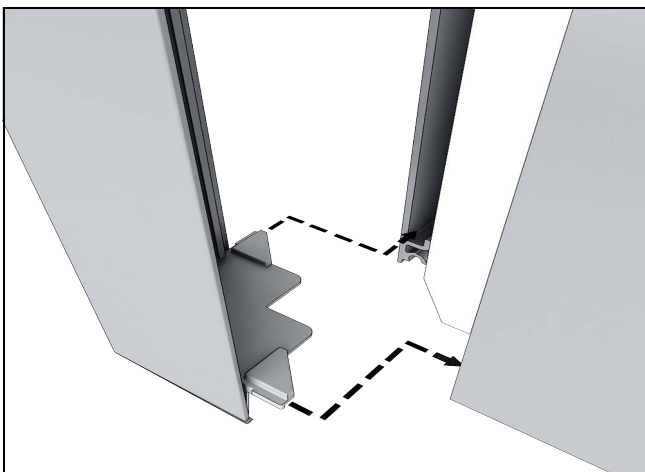

Figure 39

6. Starting at the front skirting, install modular base profile by rolling it into the front skirting profile. **Important: Verify front and side skirting is flush with unit.** See Figure 40.

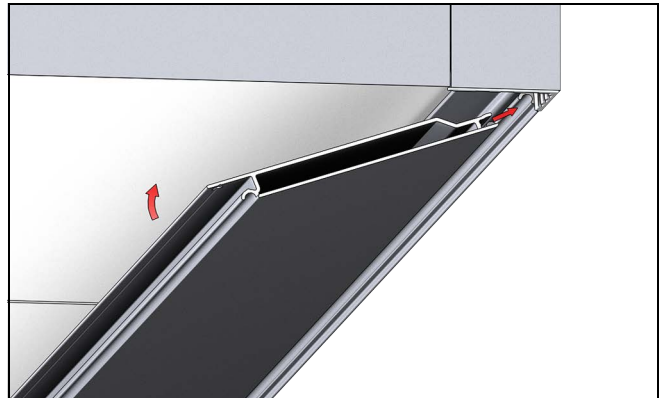

Figure 40

7. Use provided self-tapping screws to secure modular cover to both side skirts (Kit D). See Figure 41.



Figure 41

8. Install remaining modular profiles.

9. Install wall flashing flange profile by rolling it into modular base profile closest to the wall. Use 2" (51) roofing nails to fasten to the wall. See Figure 42.

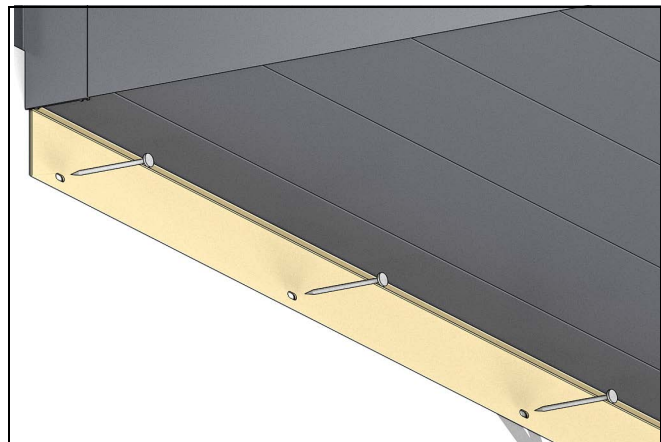

Figure 42

10. Using standard flashing detail. Install sill flashing, the jamb flashing, and finally head jamb flash to achieve weather board drainage path. See [Figure 43](#).

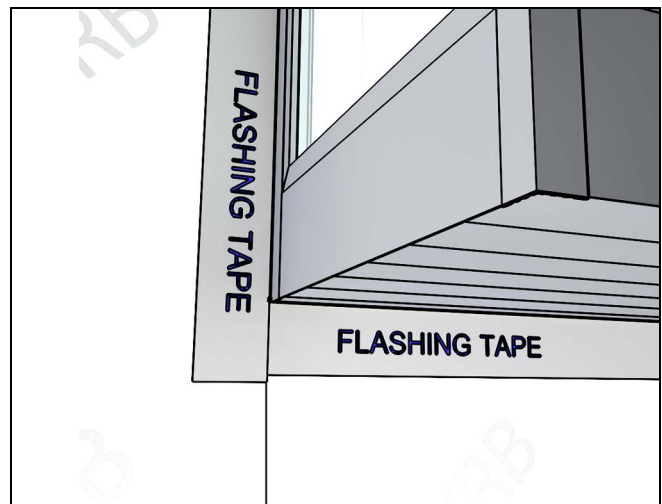

Figure 43

09. Interior Finishing

1. Using remaining foam from the foam kit, align kerf in foam with the dart feature in the Frame Support Bracket at the head jamb of the rough opening. Firmly press the foam to seat the dart feature into the kerf. Finish with remaining pieces. See [Figure 44](#) and [Figure 45](#)



Figure 44

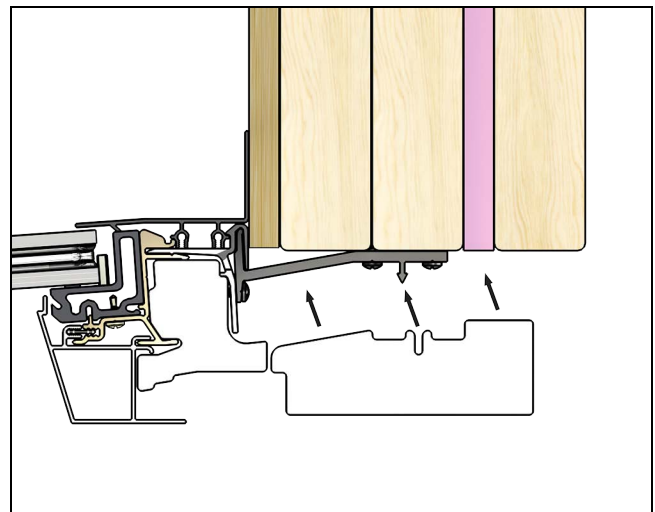

Figure 45

2. Seal between the steel upturned legs and the R.O. at both bottom corners by injecting low-expansion foam. Make sure expanding foam contacts exterior foam. See [Figure 46](#). Note: Do not fill in the hollow of sill base as indicated by red arrow.

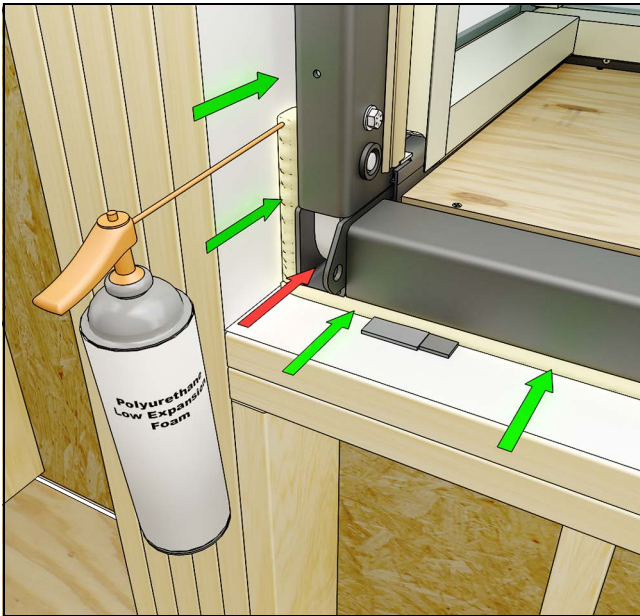

Figure 46

3. Apply sealant along sill, contact expanding foam on both side. See [Figure 46](#). Note: Do not fill in the hollow of sill base as indicated by red arrow.

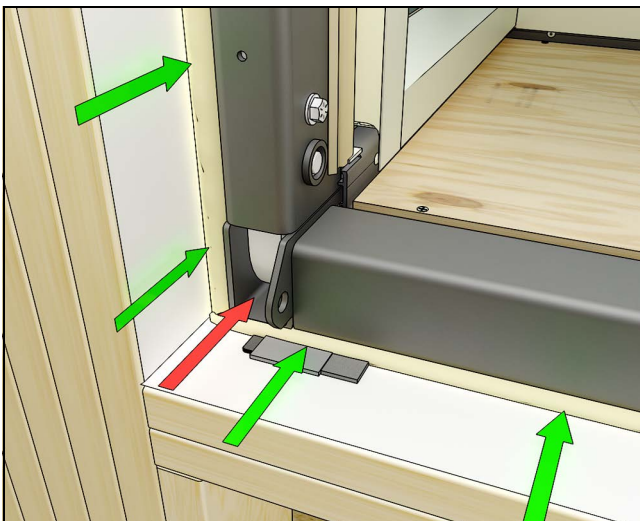

Figure 47

4. For added thermal performance, fill void between upright steel structure and rough opening with low expanding foam. See [Figure 48](#). Note: Do not fill the top of the steel tube or the channel in the head jamb foam with expanding foam.



Figure 48

IMPORTANT

Do not fill the top of the steel tube or the channel in the header foam with expanding foam. Green arrows indicate where foam should be placed. Red arrows indicate where foam should NOT be placed. See [Figure 49](#).

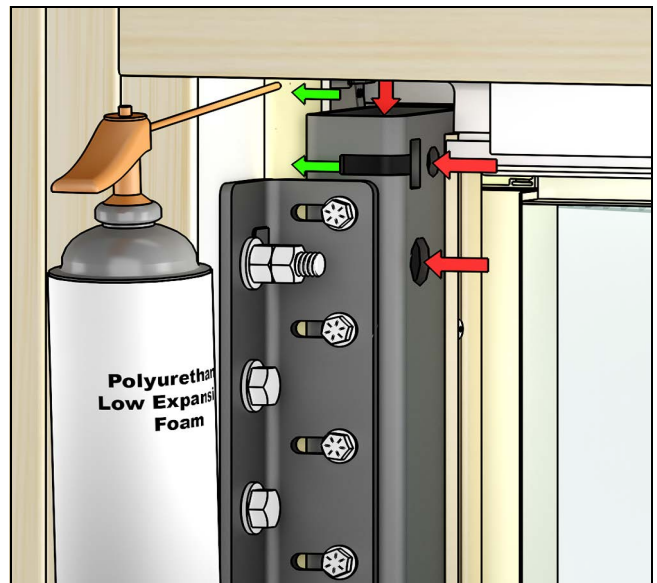

Figure 49

5. Install backer at the inside of the R.O. to act as support for both the finished seat board and sheet rock. Install pan flash to the upturned leg up onto the upturned leg and over the pre-existing pan flash to achieve weather board water management. See [Figure 50](#).

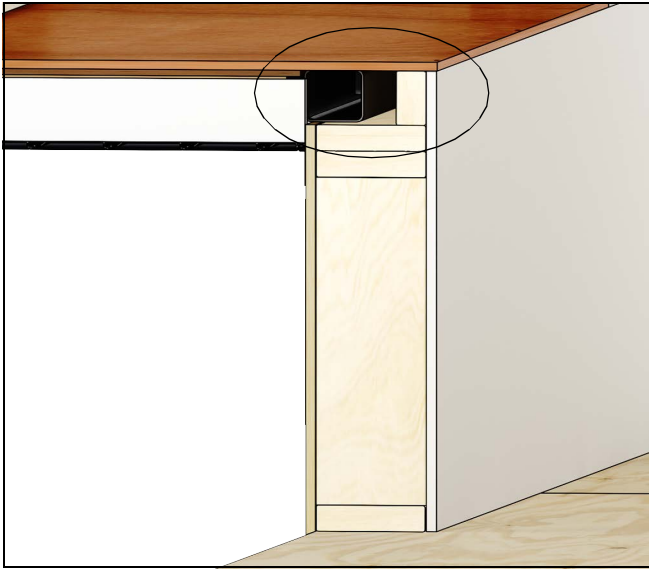

Figure 50

If ordered with unit, when installing the finished seat board, slide the seat board in and fully seat it against the vinyl bulb weather strip. *Note: Take care to not tear the side bulb weather strips while inserting the finished seat board.* See Apply sealant along sill, contact expanding foam on both side. See [Figure 51](#)

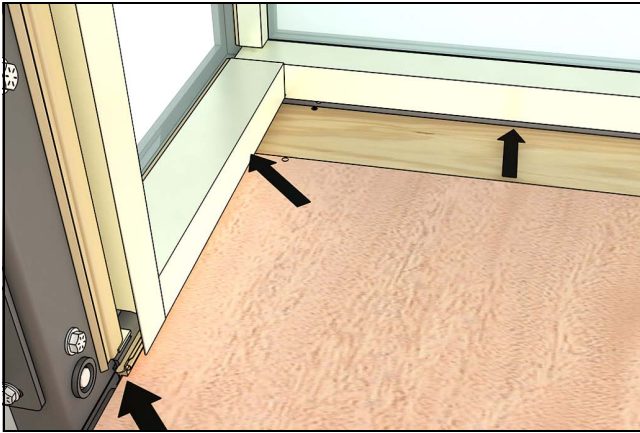

Figure 51